

# Monteringsanvisninger Sensomatic

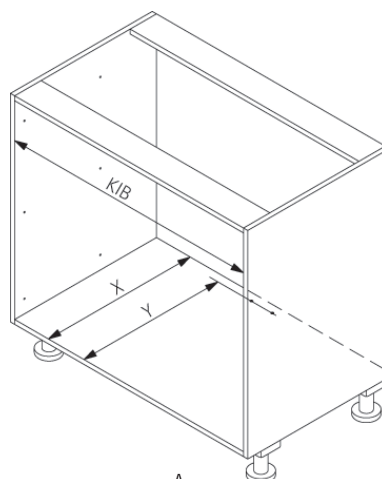

For skrog med liggende sinklist

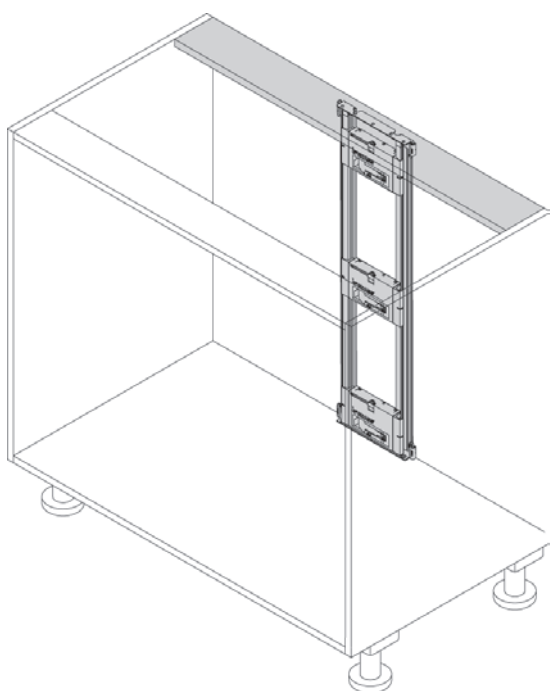

X = min. innbygningsdybde  
Y = dybde borbbilde  
KIB = innvendig skrogbredde

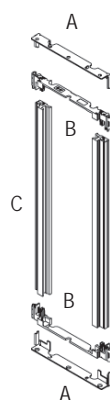

A = Traverskoping over / under  
B = Monteringsvinkel til travers  
C = Traverspar

## Innbygningsmål

Traverskoping over / under

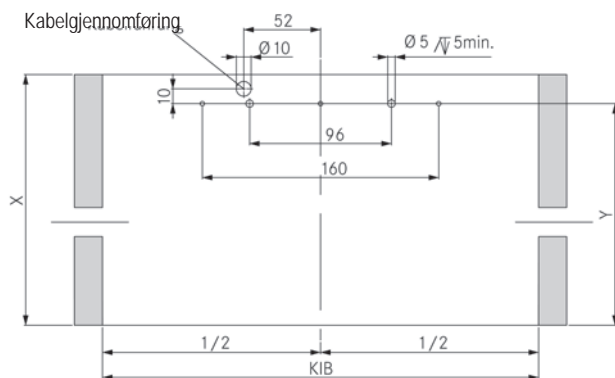
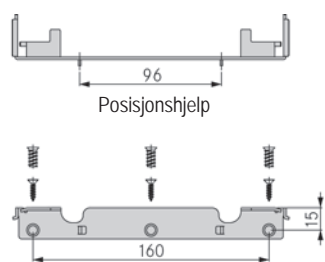

Innbygningsmål DWD XP og Agantis

X

Y

NL = Nominell lengde på skinne

Med trebakstykke

NL + 15

NL

Alle mål i mm

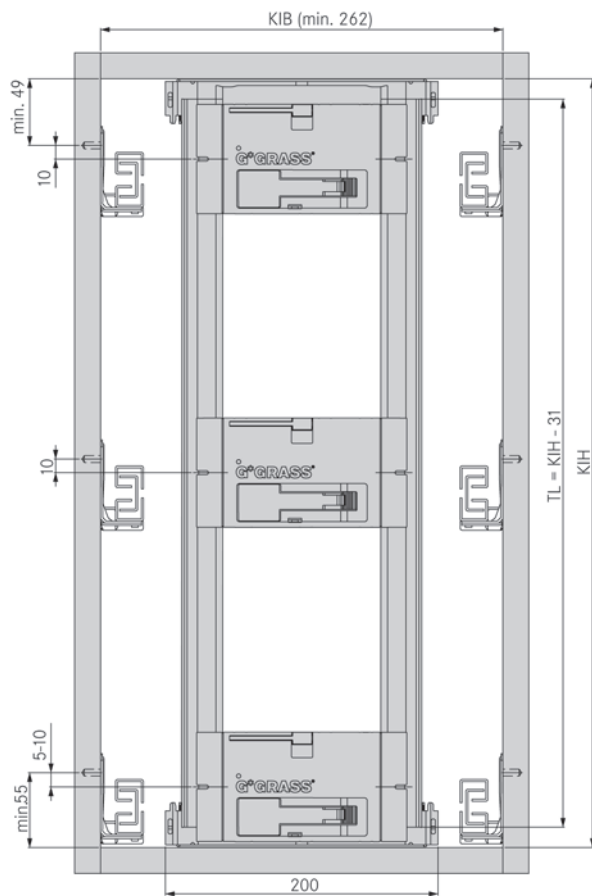

Frontbohrung

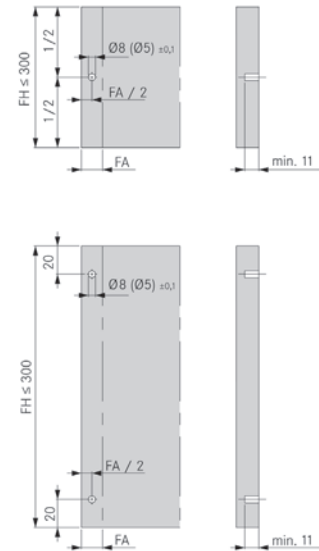

Ved bruk av 60 kg skinne må man benytte 4 tk. frontstoppere. Frontstopperne må ikke slæes eller limes inn.

KIH = Innvendig skroghøyde  
TL = Travershøyde  
KIB = Innvendig skrogbredde

FH = Høyde front  
FA = Frontoverlegg

## Kapping av traverspar

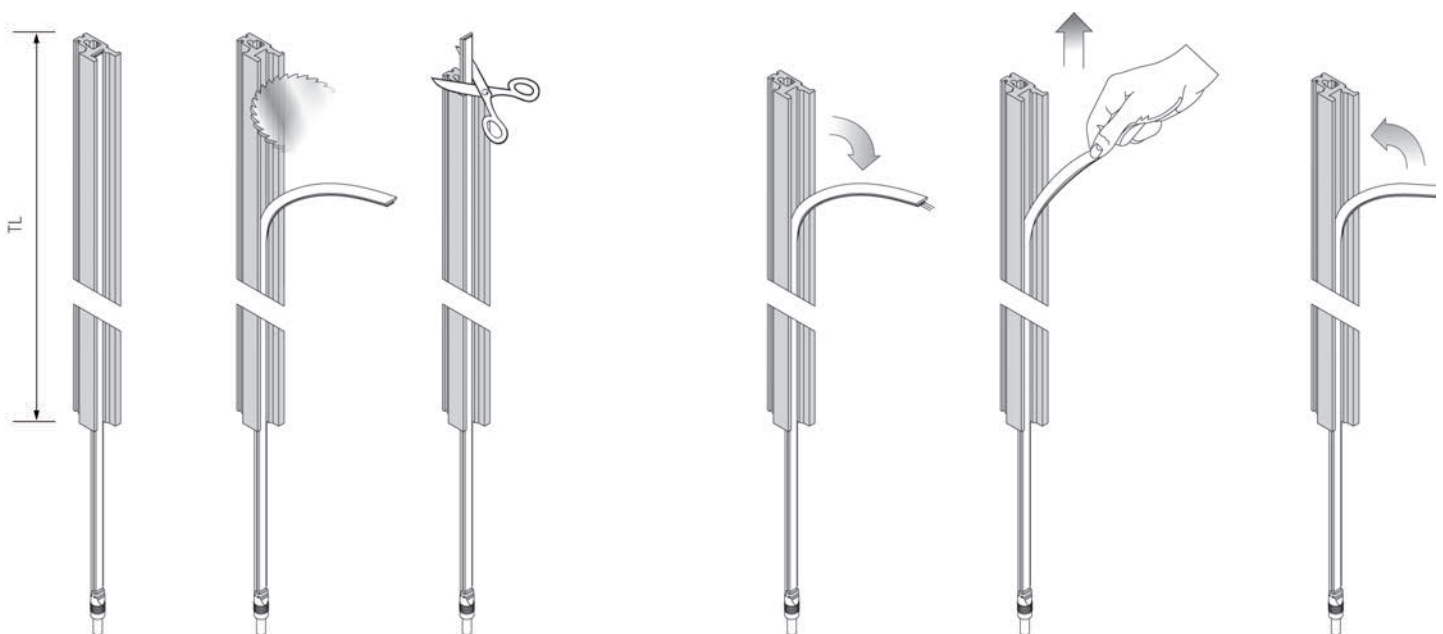

TL = Travershøyde

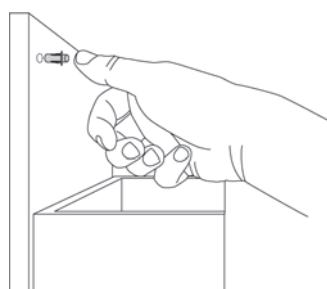
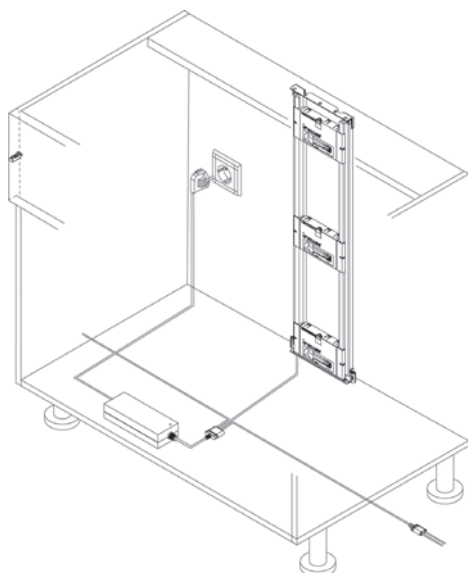
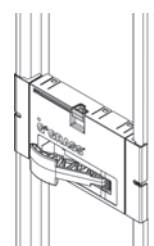
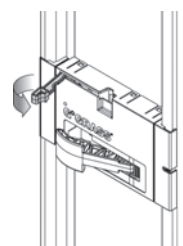
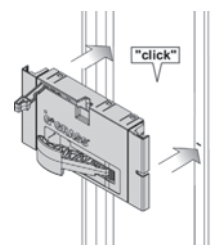
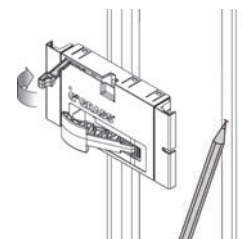
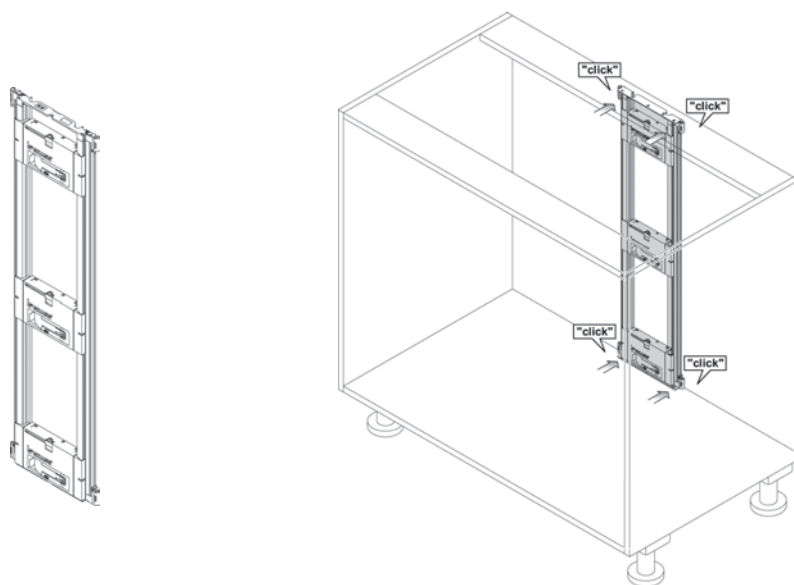
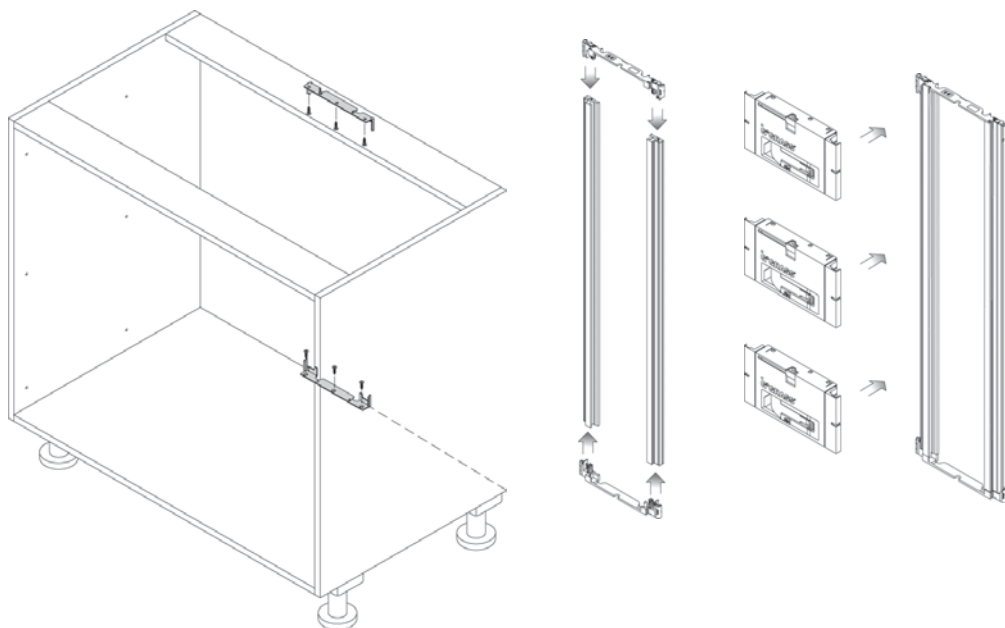

Frontstopperne må ikke slås eller limes inn.

# Monteringsanvisninger Sensomatic



For enkel skuff i topp med liggende sinklist

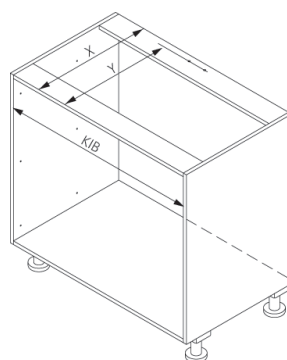
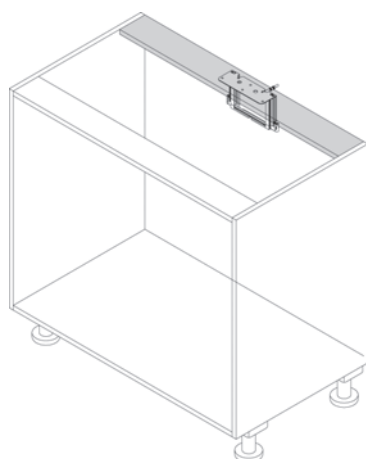

X = min. innbygningsdybde  
Y = dybde borrbilde  
KIB = innvendig skrogbredde

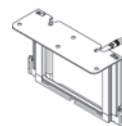

## Innbygningsmål

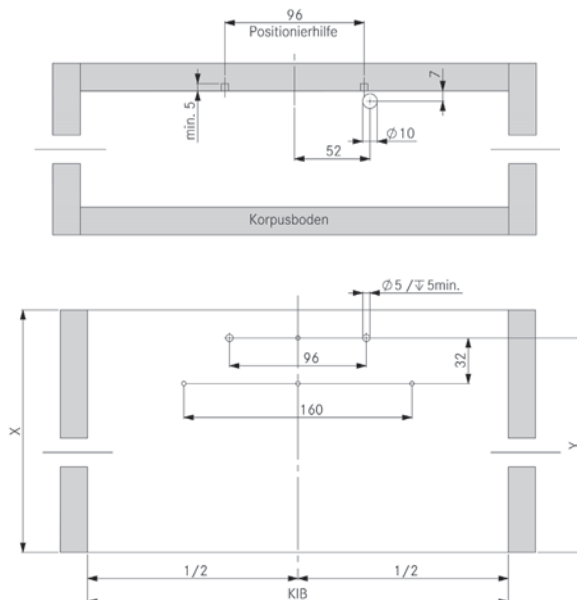
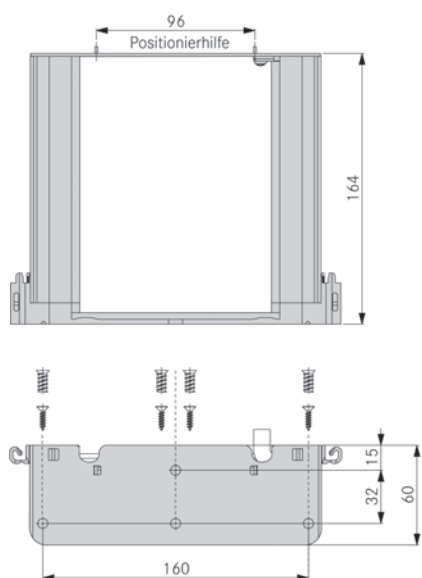

Innbygningsmål DWD XP og Agantis

X

Y

NL = Nominell lengde på skinne

Med trebakstykke

NL + 15

NL

Alle mål i mm

## Posisjonering av utkastenehet

## Posisjonering av frontstopper m/fjær

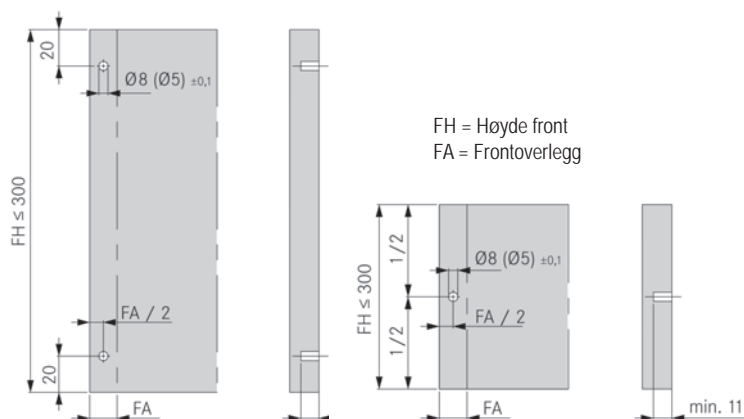
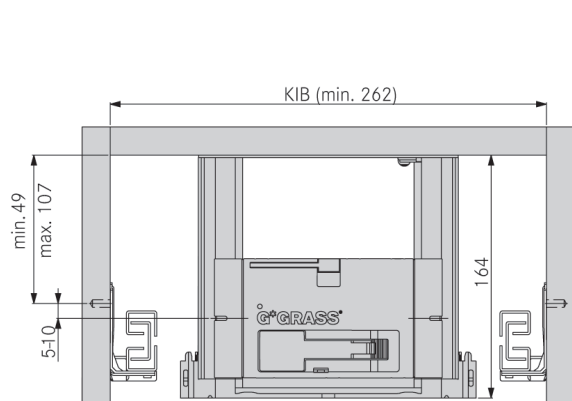

FH = Høyde front  
FA = Frontoverlegg

Ved bruk av 60 kg skinne må man benytte 4 tk. frontstoppere. Frontstoppene må ikke slås eller limes inn.

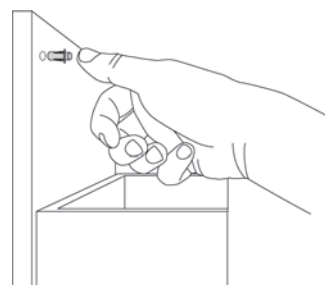
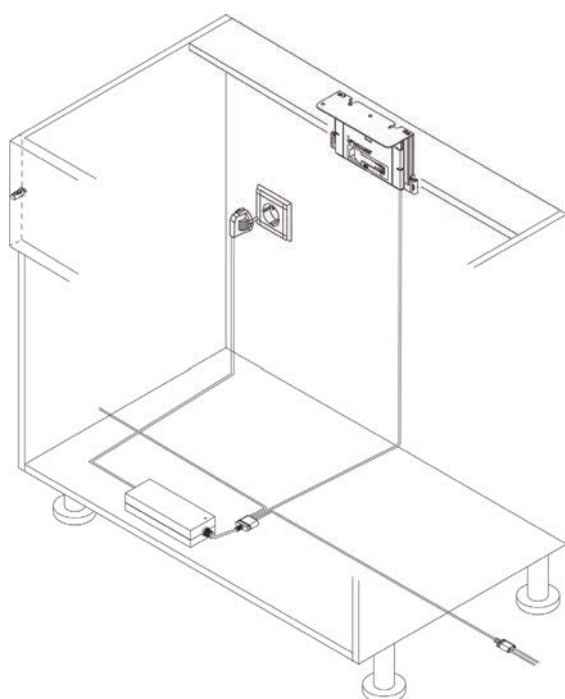
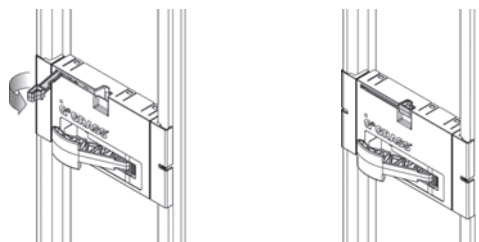
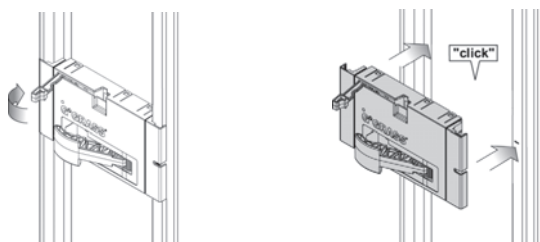
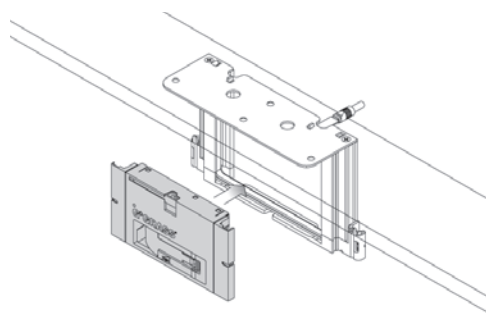
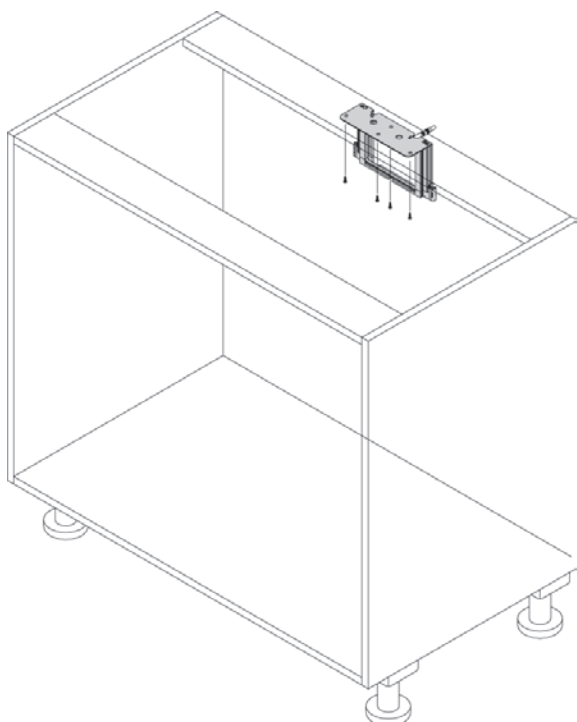

Frontstopperne må ikke slås eller limes inn.

# Monteringsanvisninger Sensomatic

For enkel skuff i bunn med bunnmontasje

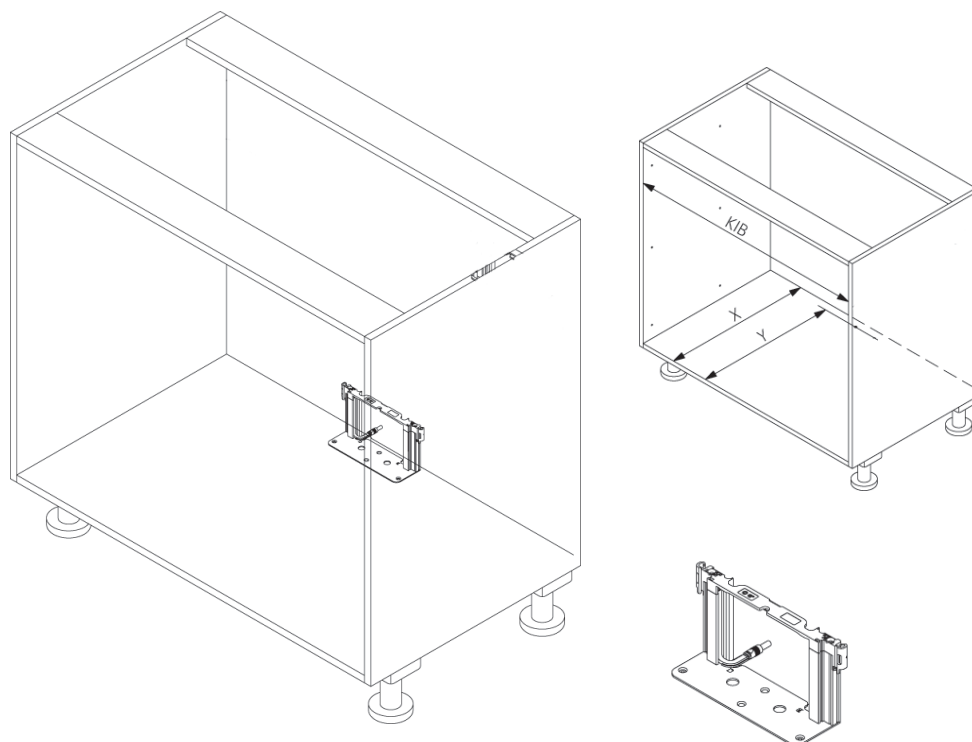

X = min. innbygningsdybde  
 Y = dybde borrbilde  
 KIB = innvendig skrogbredde

## Innbygningsmål

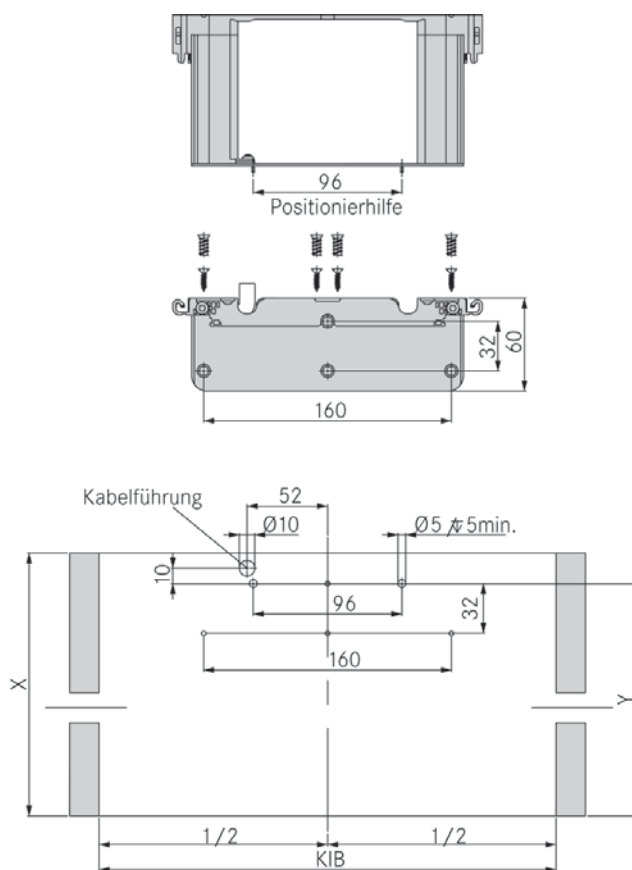

Innbygningsmål DWD XP og Agantis

X

Y

NL = Nominell lengde på skinne

Med trebakstykke

NL + 15

NL

Alle mål i mm

## Posisjonering av utkastenehet ved bunnmontasje

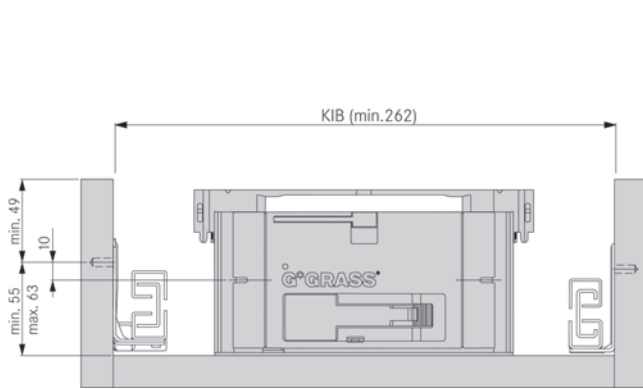

KIB = innvendig skrogbredde

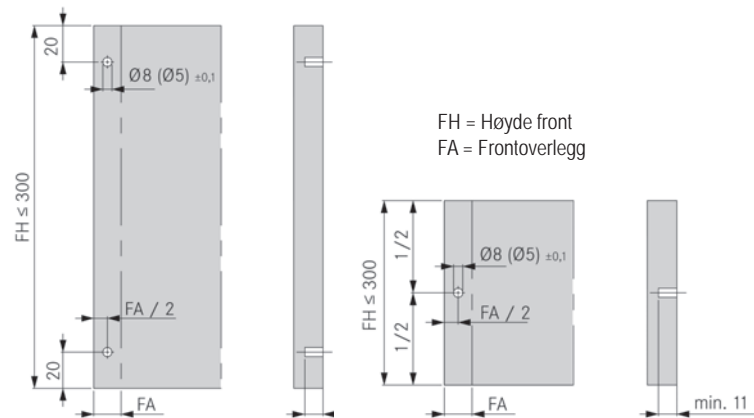

Ved bruk av 60 kg skinne må man benytte 4 tk. frontstoppere. Frontstoppene må ikke slås eller limes inn.

## Montering av utkastenehet ved bunnmontasje

## Kabling og montering av frontstoppere

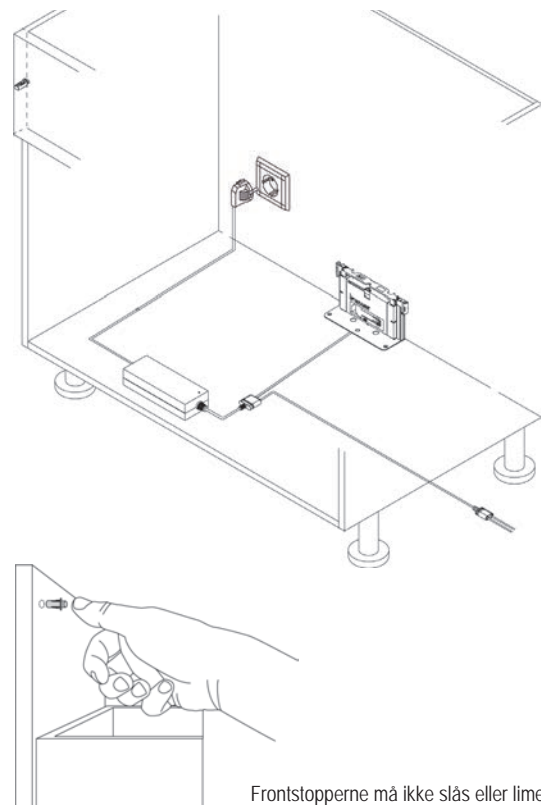
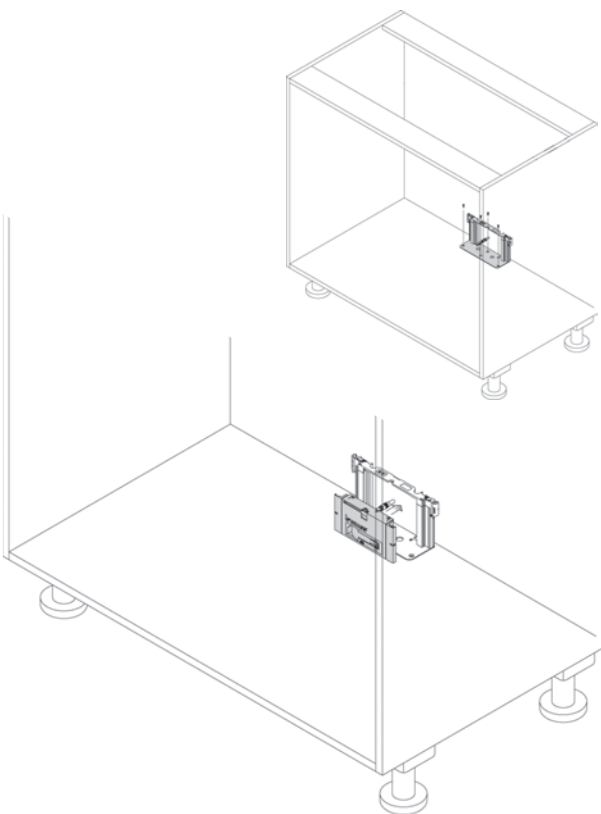

Frontstoppene må ikke slås eller limes inn.

